

Drive: Roller Chain
Release: Remote Electrical & Mechanical, Local Mechanical
Security Level: Maximum

2B.3 SLIDING DOOR LOCKING DEVICE

Description

Type 2B.3 locking devices are high security, motorized sliding cell door operating and locking systems for use with any doors not exceeding 300 pounds.

Applications

2B.3 devices are applicable to any multiple cell or inmate room door situation. Optional controls provide selective operation of single or groups of doors simultaneously.

Functions

Unit unlocks, opens and deadlocks open, or closes and deadlocks closed, pre-selected individual doors or door groups, via optional electric controls. Gang release is by mechanical release cabinet.

Door movement may be stopped in mid-travel. The door is not free-wheeling in the electrical mode. Pressure exerted by a door in travel is factory set at approximately 40 pounds. Force is adjustable between 20 and 50 pounds.

Direction of travel of any individual or selected group of doors may be reversed without interrupting the operation of other doors.

When a single door is blocked, there is no interruption in the operation of any other door in the group. On removal of the blockage, the door will automatically continue movement to the open or closed position.

In event of emergency or power failure, any door may be unlocked manually at



the door, and moved by hand without changing the locked status of any other doors.

In event of power failure, doors may be manually opened or closed by sliding the door.

Locking System

Upon closure, each door automatically deadlocks at two concealed points at the rear edge of the door. Upon opening, each door automatically deadlocks open at the front edge of the door. Locking components are not exposed at the front edge of the door and, therefore, not subject to tampering. Components do not project into the door opening.

Testing

Type 2B Series has been in service since 1962, and this system has been tested at 500,000 cycles.

Standard Features

- **Motor voltage** – 120 VAC.
- **Plug-type connectors** – Simplified wire harness installation.
- **Rugged chain drive** – Provides consistent action of the door under a variety of conditions and installation variables.
- **Heavy duty construction** – 2B.3 devices are built for the rigors of maximum security applications.

2B.3 SLIDING DOOR LOCKING DEVICE

- **Tamper-resistance** – Openings in housings are baffled to resist inmate tampering.
- **Selective operation** – Single or groups of doors may be simultaneously opened or closed and deadlocked.
- **Adjustable torque limiter** – Simple adjustment of force exerted by the door. May be set between 20 and 50 pounds.
- **Sloped-top housing** – Resists hiding of contraband. Flat-top housing provided where device must install close to ceiling.
- **Fixed hinge cover** – Allows maintenance without the need to lift heavy covers off the device.
- **Cover lock** – Device mechanisms are concealed by an outer cover and unlocked from the release cabinet.
- **Automatic deadlocking** – When fully closed or open, independent top and bottom locking points on the rear of each door automatically deadlock.
- **Indication switch** – Monitors the deadlocked condition of both locking points.
- **Gang release** – From mechanical release cabinet.
- **Self-contained** – A continuous, surface-mounted housing contains the drive and mechanical release mechanisms and wiring.
- **Removable end battens** – Simplify installation of wire harnesses.

- **Full length wire tray** – Simplifies routing of electrical wire/harnesses. Runs the full length of the housing.

Optional Features

- **Key switches** – May be added in columns or nearby for local electric control.
- **Two point locking mechanical release cabinet** – A three-position lever handle or crank handle is provided. Lever provides:
 1. Electric operation – Door control from a remote location.
 2. Release ports open – Opening of individual release ports. Doors to be individually released at the door with a removable handle. Covers are also individually released from the port.
 3. Emergency unlock – Gang release of all doors in event of emergency or power failure.
- **Electrical/mechanical control cabinet** – Electrical switches may be ordered to provide control of each door in addition to mechanical function. These switches may be built into the same cabinet as the mechanical levers, or located remotely as required. The following switch functions are available:
 - **Three-position operating switches** – (OPEN-GROUP-CLOSE).
 - **Group switch** – Provides group control (OPEN-OFF-CLOSE).

■ **Power cut-off switch** – Cuts off electrical current to controls.

■ **Indication lamps** – Red and green indicator lamps may be installed with switches to show deadlocked, closed, or open status of each door.

- **Special indication lamps** – An additional (amber) lamp is available. When used, indication is as follows:
 - Red - Locked open.
 - Green - Deadlocked closed.
 - Amber - Moving, or stopped in mid-travel.

■ **Custom graphic controls** – In many cases, it may be desirable to separate electric controls from the mechanical release cabinet located near the cells. For larger installations, or those with particular needs, custom-built control consoles may be easily provided with floor plan graphics screened on the control panel, and an array of specialized features.

■ **Wire harness** – For applications using a series of locking devices, a wire harness(es) may be specified to interconnect terminal strips in the mechanical control/release cabinet to a plug connector at the door operating unit. Simplifies routing of wire, and saves installation cost and time.

■ **G90 galvanized finish available.**



Drive: Roller Chain
Release: Remote Electrical & Mechanical, Local Mechanical
Security Level: Maximum

2B.3 SLIDING DOOR LOCKING DEVICE

Specifications

■ Drive system –

Rate of travel: Opens or closes a 30" door in approximately 6 seconds.

Motor: 120 VAC, 60 HZ, 1/20 HP.

Roller chain: #41 size.

Hanger and guides: 1/4" thick steel.

Rollers: Cold formed steel. Rollers are mounted on hardened ball bearings protected by internal grease shields.

Finish: USP.

■ Mechanism housing/covers –

Housing: 7-gauge steel.

Housing covers: 10-gauge steel, hinged to housing.

Vertical lock column housing: 1-1/2" x 2" x 11 gauge steel tubing on solid steel cast bottom.

Wire tray: 16-gauge steel tray.

Front receiver column (optional): 10-gauge steel.

Finish: USP primed.

Typical 2B.3 slope-top elevation.

Left hand (LH) as shown.

Right hand (RH) opposite as shown.

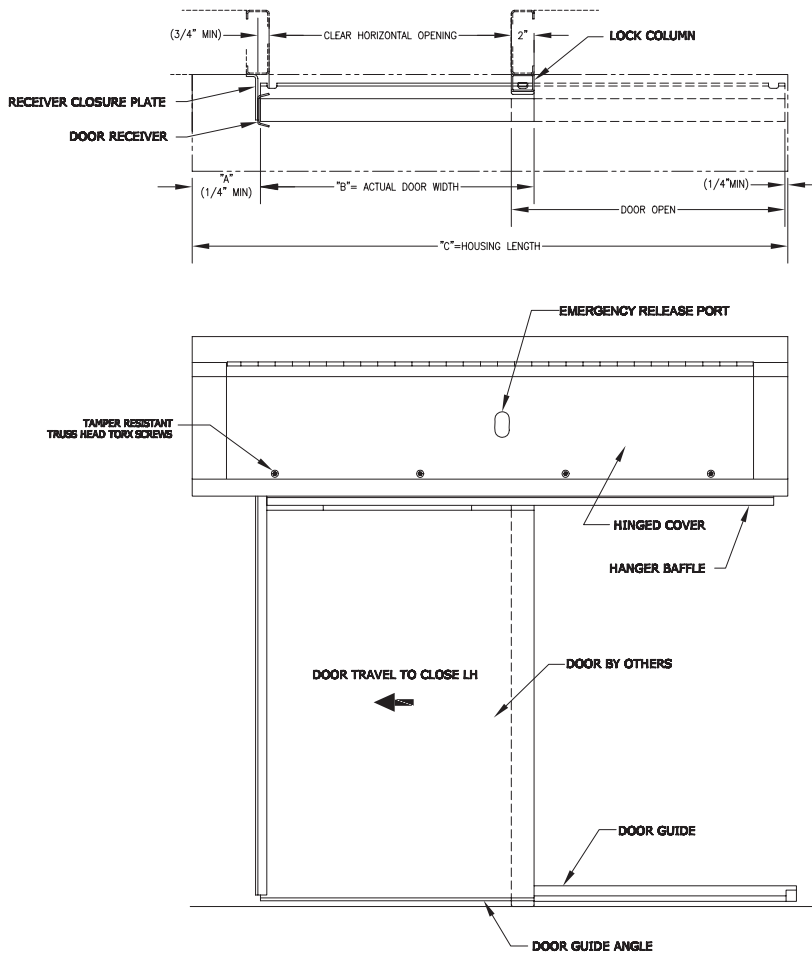

Dimensional Data

Note: Dimensions are for information and planning purposes only, and should not be used as templates.

The illustration shown is intended for general information and planning purposes only. Folger Adam locking devices are fabricated to the design of the facility.

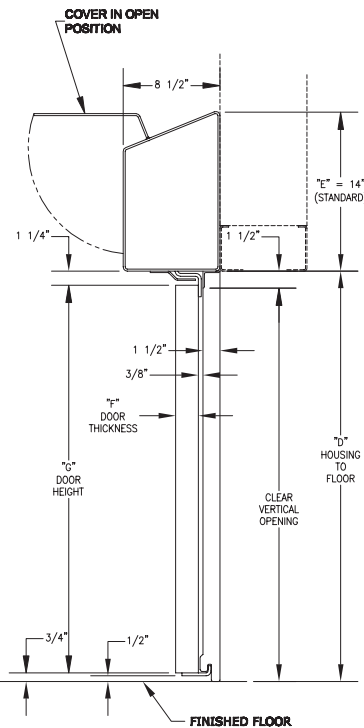

ALSE MEXICANA S.A. DE C.V.
 Santa Beatriz No. 3722, Col. Jardines de San Ignacio, Zapopan 45040, Jal. Tel. (33) 3121 7878 Fax (33) 3121 9131
 www.alsemexicana.com info@alsemexicana.com Lada sin costo: 01-800-001-ALSE

