

Key: Prison Paracentric
Door: Swinging
Security Level: Medium

15 Latch

DESCRIPTION:

No. 15 Latches are lever tumbler, mechanical locks for small swinging doors. **Keyed one side only.**

APPLICATIONS:

No. 15 Latches are ideal for use on observation panels, wicket or other small doors or covers. The latch is concealed by the case to preclude tampering when closed. Not for use on full size doors. Specify handing.

STANDARD FEATURES:

- **Mechanical operation**—Unlocks by key, locks when door is closed.
- **Automatic snap-locking**—When the door is closed.
- **Durable case**—Malleable iron case with 1/4" thick cold drawn steel cover.
- **Corrosion-resistance**—Working parts are corrosion-resistant.
- **Heavy duty lever tumblers**—5 spring-temper brass tumblers, activated by heavy phosphor bronze springs. Precision fit to locking fence.
- **Large, solid latchbolt**—Solid bronze, 1" x 7/16", fully concealed.
- **Bolt throw**—7/16".
- **Investment-cast key cylinder**—One-piece bronze alloy with paracentric keyway.



Right hand shown

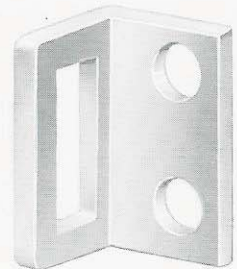

- **Supplied**—With angled strike, and four 1/4-20 x 1-1/2" flat head security screws.
- **Finish**—Standard is USP.

HOW TO ORDER:

Specify:

1. Quantity
2. Handing
3. Mounting required
4. Key code instructions

DIMENSIONAL DATA:

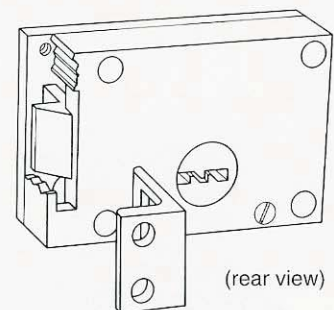
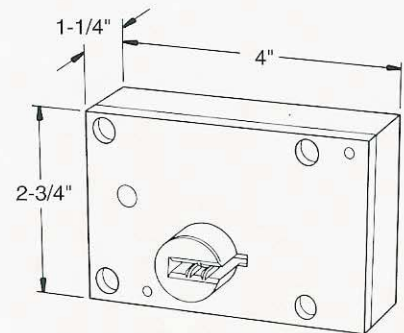

(rear view)

NOTE: Dimensions are for information and planning purposes only, and should not be used as templates.



Santa Beatriz No. 3722,
 Col. Jardines de San Ignacio,
 Zapopan 45040, Jal.
 Tel. (33) 3121 7878
 Fax (33) 3121 9131
 www.alsemexicana.com

Dakota No. 69
 Col. Nápoles,
 México 03810, D.F.
 Tel. (55) 5543-1938
 Fax (55) 5543-2835
 info@alsemexicana.com

Lada sin costo: 01-800-001ALSE
 (2573)